

# **Critical Evaluation of the Motorola M12+ GPS Timing Receiver vs. the Master Clock at the United States Naval Observatory, Washington DC.**

**Richard M. Hambly**

CNS Systems, Inc., 363 Hawick Court, Severna Park, MD 21146-1409

Phone 410-987-7835, Fax 410-987-7836

e-mail rick@cnsys.com, Web <http://www.cnsys.com/>

**Dr. Thomas A. Clark**

Syntonics LLC, 9250 Bendix Road, North Columbia, MD 21045-1800

Phone 410-480-7200, Tom.Clark@SyntonicsCorp.com

## *Abstract*

*The paper describes the challenge of calibrating a new GPS Timing receiver so that its timing performance can be characterized with traceability to true UTC. This effort involved development of a custom test bed with improved software, installing the test bed at USNO, calibrating all the elements of the USNO and test bed equipment, collecting the data, and data analysis. This test bed allows testing of four GPS Timing receivers simultaneously so that variations in the manufacturing process and "zero baseline" comparisons can be evaluated. The work was extended to include a test of the level of synchronicity obtained between receivers separated by a 21.5 km baseline.*

## **INTRODUCTION**

During a series of tests on low-cost GPS timing receiver modules<sup>1,2</sup> it was noticed that the average time produced by the receivers varied over a range of about 150 nanoseconds when measured against the site's Hydrogen Maser. This occurred even between various firmware releases from a single manufacturer on the same hardware.

When Motorola decided to release the latest in their family of GPS timing receivers they took note of these results and asked CNS Systems to perform calibration testing of a representative sample of their new M12+ receivers against the master clock at USNO so they could be calibrated to UTC.

---

1 Low-cost, High Accuracy GPS Timing presented at the Institute of Navigation's GPS 2000 Conference, September 20, 2000 by Dr. Thomas A. Clark, NASA Goddard Space Flight Center, Greenbelt, Maryland, Richard M. Hambly, CNS Systems Inc., Severna Park, Maryland, Reza Abtahi, CNST, San Jose, California. Text is available from <ftp://www.gpstime.com/pub/ION-GPS2000/ion-time.pdf>.

2 PowerPoint version of ION paper is at <ftp://www.gpstime.com/pub/ION-GPS2000/ion-time.ppt>.

## **THE TEST BED**

The CNS Test Bed has been developed to perform calibration and testing of any GPS timing receiver that produces a one-pulse-per-second (1PPS) output. To get a representative sample of receiver data, the test bed is sized to simultaneously test four receivers. The architecture is an extension of the master clock monitoring facility developed for NASA's Very Long Baseline Interferometry (VLBI) Geophysical Observatory sites around the world. It is based on the use of a Time Interval Counter (TIC) coupled with a computer that controls the GPS receiver module and performs data collection, reduction, statistical computations and logging.

The Test Bed can be seen in Figure 1. Data collection was anticipated to be about 10Mb per day. The computer also simultaneously collects data from four TICs and interface with four GPS receivers using eight serial ports. This requires a high performance Personal Computer with plenty of disk storage, eight high performance serial ports, and fast enough to run four copies of the Tac32Plus software and respond quickly to many interrupts.

## **CALIBRATION**

Calibration of the Test Bed was the most critical step in preparing for data collection, as the sum of calibration errors would set the limits of calibration performance.

Short cables with connectors were calibrated using an Agilent 8595E Spectrum Analyzer with tracking generator and an assortment of directional couplers by observing the unterminated cable's effect on a resonant circuit.

Longer cables and the 1PPS distribution amplifier were measured by feeding a 1PPS signal from a USNO Hydrogen Maser through the cable and observing the delay on an Agilent 53132A Time Interval Counter, while maintaining correct termination impedance. Ed Powers of USNO assisted with these tests.

The GPS antenna, main cable and USNO's distribution amplifier had previously been calibrated by USNO staff using an HP 8719D (13.6GHz) network analyzer. Ed Powers of USNO calibrated the additional L1 signal splitter using this same network analyzer.

The final results were carefully reviewed with the assistance of Ed Powers and are shown in Figure 2.

## **PRE-CALIBRATION RESULTS**

The four Motorola M12+ receivers were tested and evaluated against UTC, accounting for the calibration offsets in the Test Bed. A sample of the pre-calibration results is shown in Figure 3. The missing data from late on 1-Aug (UTC) through mid-day on 2-Aug was due to a power failure at USNO. After this happened two more times we realized that this was the peak time of year for lightning, so we changed the power source to run off fully protected and backed up power. Fortunately there was no damage to any of the equipment.

The receivers were all found to perform similarly with their 1PPS signals each about 84 nanoseconds early. Receiver-to-receiver tracking was very good, within a few nanoseconds. These results were sent to Motorola, the receiver firmware was updated and reloaded into the receivers and testing resumed.

## POST-CALIBRATION RESULTS

Once the receivers had their revised firmware, the tests were repeated. This time the receivers were each very close to zero offset relative to UTC. The receiver shown in Figure 4 averaged 0.2 nanoseconds early over the more than 12 day period shown.

Notice the unusual excursion late on 7-Sep followed by two rebounds over the next three days. It turns out that during this period Dr. Thomas A. Clark was photographing the night sky in Howard County Maryland (approximately N39° W79°) with his Cannon D60 digital camera. He captured a fairly rare and spectacular red and green aurora borealis display that commenced immediately after the peak shown on the chart. Additional data was collected and analyzed through mid-November with no repeats of either unusual data excursions or aurora displays

Figure 5 shows the tracking of the four receivers referenced to the “A” receiver. The “B” receiver tracks almost perfectly, while the “C” and “D” receivers are late by about 5 nanoseconds. This has been traced to a variation in group delay for the M12+ IF filters that came from two different production lots. It is hoped that the specifications will be tightened on these filters to minimize this offset in the future.

The one hour short term 1PPS noise for the post-calibrated M12+ Timing receiver is shown in Figure 6. The raw 1PPS shows the expected noise dominated by the quantization of the samples at twice the clock frequency of 16.367MHz.

$$\frac{1}{2 * 16.367 * 10^6} = 30.55n\text{sec } pk - pk$$

The line down the center of the short term noise chart shows the effect of applying the sawtooth correction factor provided each second by the M12+ receiver to the raw data provided by the Time Interval Counter. This allows for real time correction of the quantization error and reduces the residual noise to about 5 nanoseconds pk-pk.

## SYNCHRONICITY

Many timing applications are more concerned by the degree to which two isolated timing receivers keep the same time. During the same period shown in Figure 4, a similar M12+ was being used at the NASA GGAO VLBI site, 21.5 km from USNO. Since both sites employed a Hydrogen Maser clock as their fundamental timing reference, we had an opportunity to test the differential timing performance of two separated M12+ receivers.

The results of this test are shown in Figure 5, comparing the performance of the “A” receiver at USNO (blue) with GGAO (red). The ~1.2 usec “DC” offset at USNO and a small (< 1:1014) linear drift have been removed from the USNO data. Similarly, a ~6.8 usec “DC” and ~1:1013 rate offset have been removed from the GGAO data. Because of differences in the data acquisition at the two sites (100 second samples at USNO, 60 seconds at GGAO), the raw data has been smoothed to yield common 5 minute samples. Clearly, the two data sets are in close agreement, even during the ~40 nsec transient associated with the September 8th solar event.

Figure 5 also shows the point-by-point timing differences between the two sites. The RMS difference between the two sites is 4.2 nsec, while the absolute peak-to-peak range is 30 nsec. A part of this is like due to small ( $< 1$  nsec/day/day) rate changes between the underlying Hydrogen Maser “flywheels”.

## CONCLUSION

By evaluating the performance of the new M12+ timing receiver against the USNO’s UTC clock the manufacturer has been able to compensate for the internal delays in the M12+ and the resulting product is now well characterized and its performance is traceable to UTC. In addition we now have four “gold standard” receivers whose specific performance is reasonably well understood. These receivers can be used as lab standards for evaluating other receivers.



**Figure 1: The CNS Test Bed**

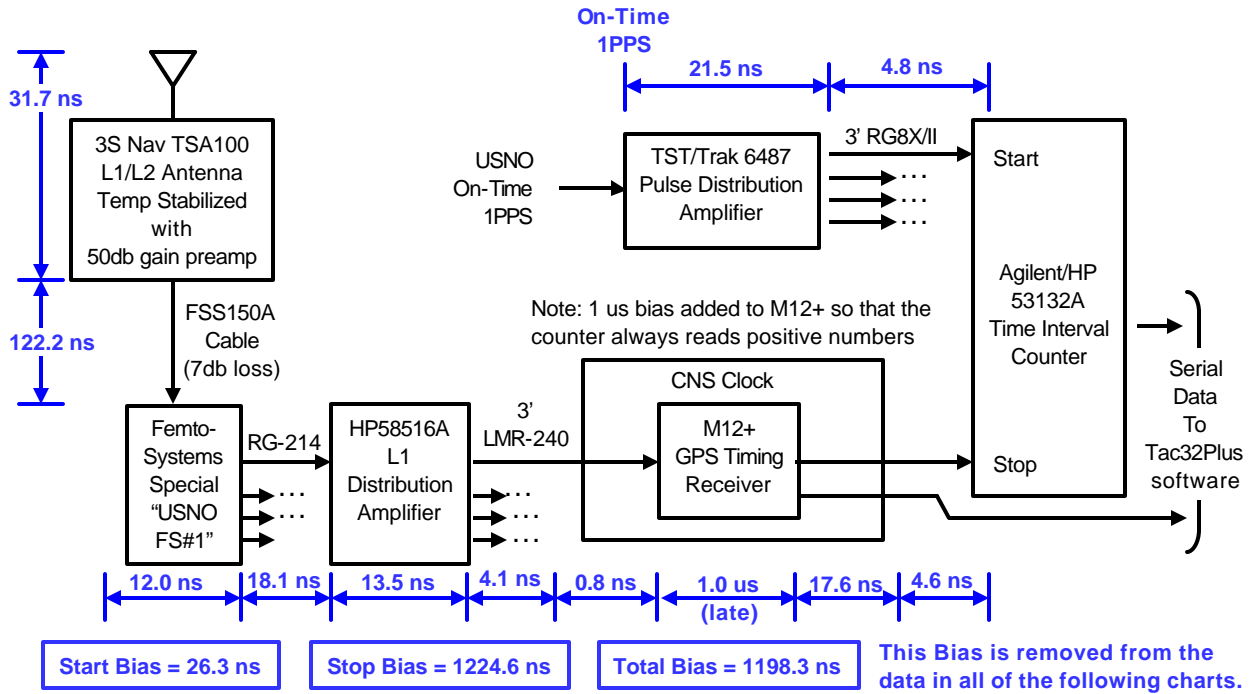

Figure 2: Test Bed Calibration

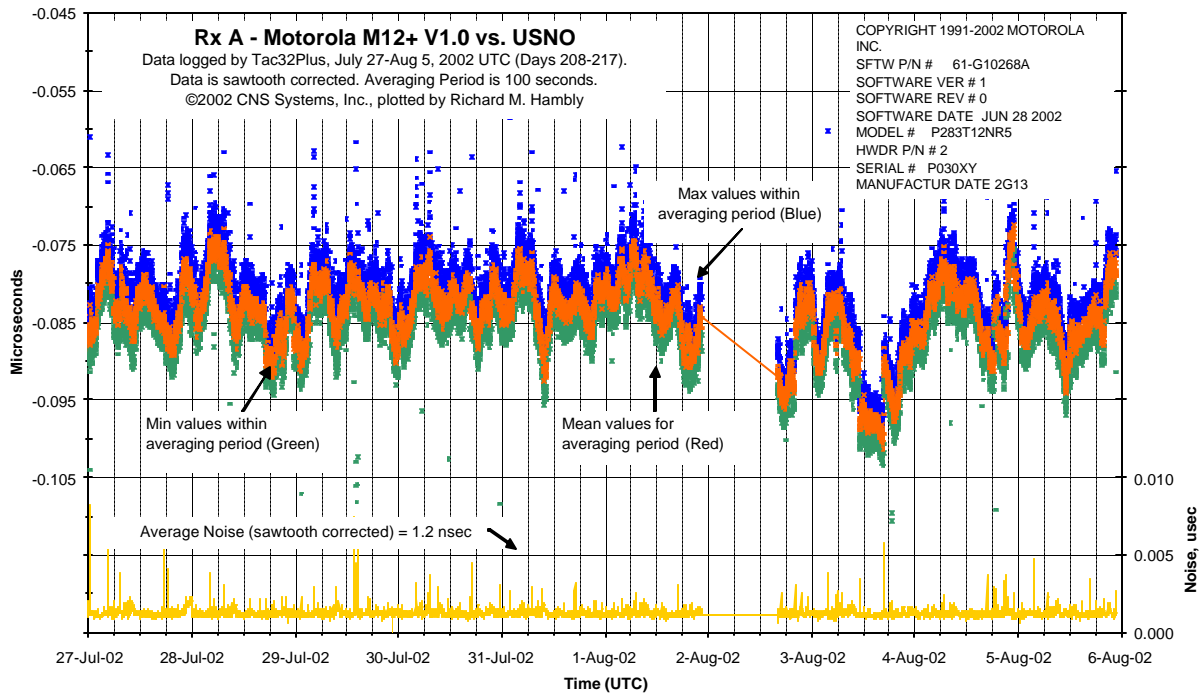
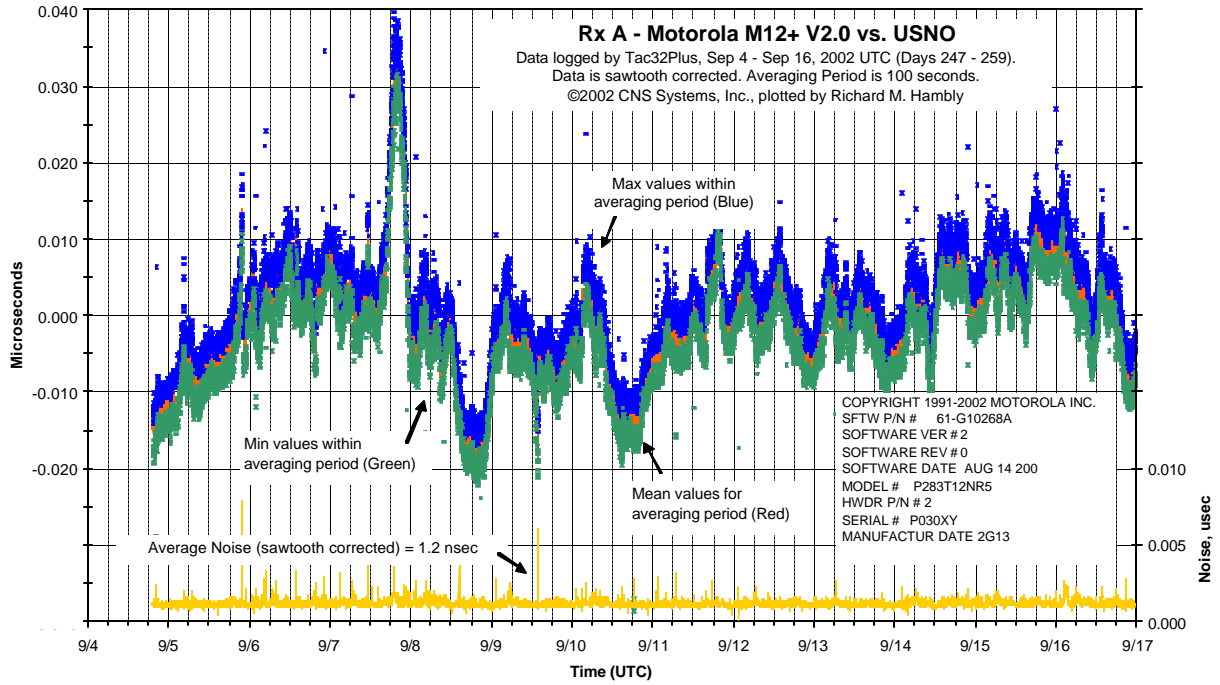
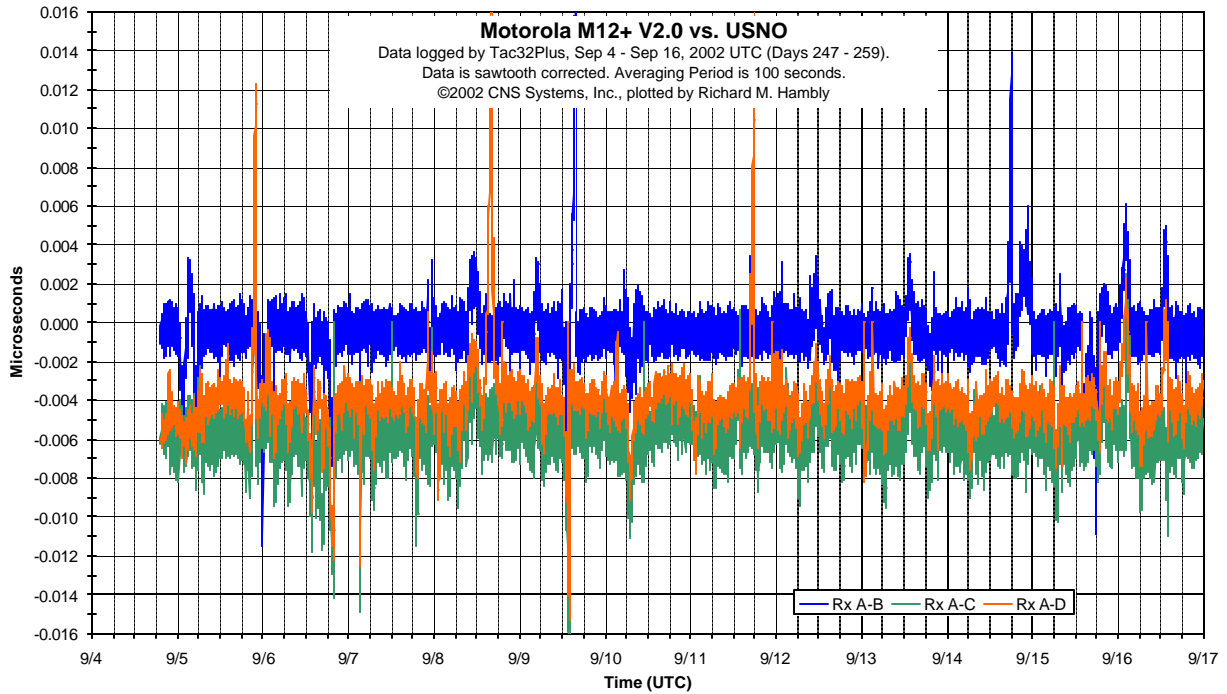

Figure 3: Pre-Calibration Results



**Figure 4: Post-Calibration Results**



**Figure 5: Result Tracking - Four Receivers**

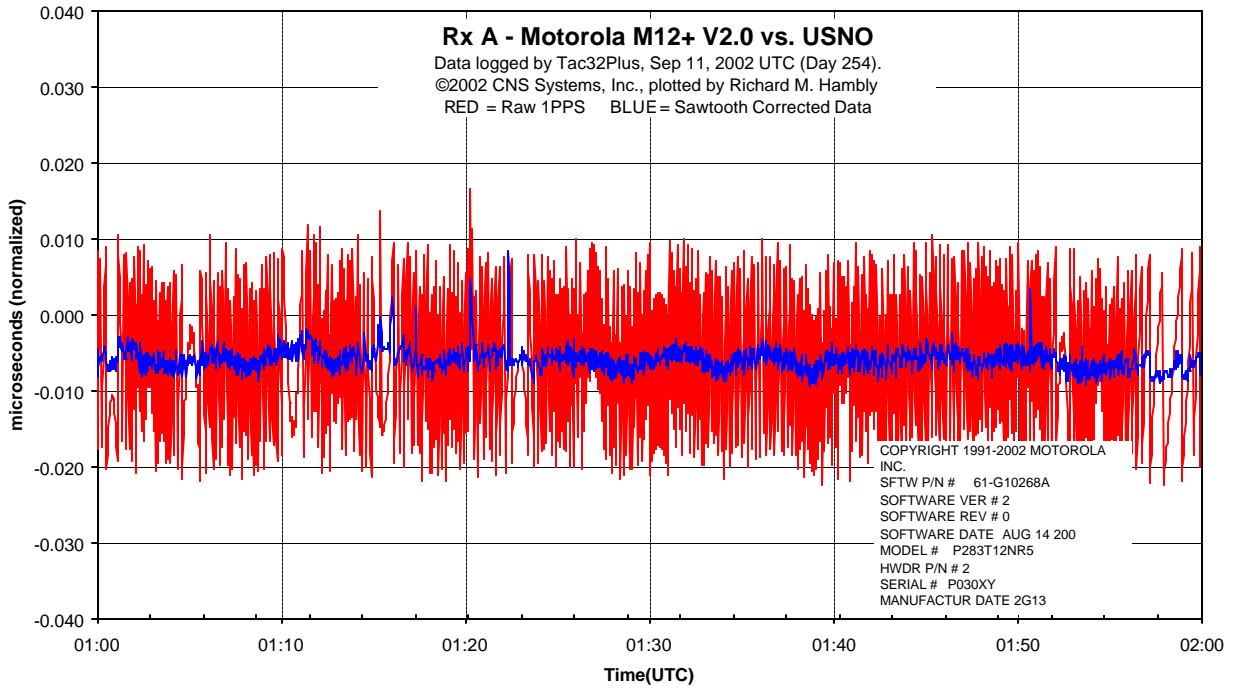

**Figure 6: Short Term 1PPS Noise**

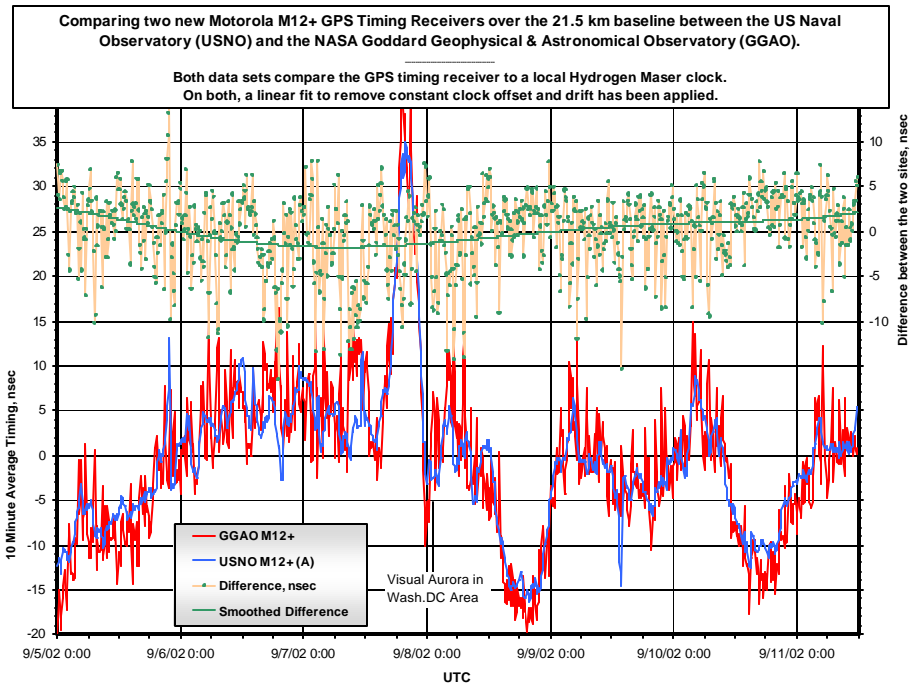

**Figure 7: 21.5 km Baseline Test**